

ASOPS

Asynchronous Optical Sampling System



In time-resolved measurements an ultrafast pulse triggers a reaction and a second pulse takes a snapshot of the induced change. By shifting the arrival time of the probe pulse with respect to the pump pulse the stimulated process can be followed in time. The asynchronous optical sampling technique allows high-speed scanning over some nanoseconds of time delay without a mechanical delay line. The ultrafast lasers delivering the pump and probe pulses are locked together at a tunable repetition rate difference.

The lasers can be also locked to the same repetition rate value and by shifting the relative phase between the laser pulses, the system will allow measurements in a reduced time window of some 100 ps. Switching between the two modes of operation can be done at the touch of a button.

ASOPS TWIN 250 LASER HEADS

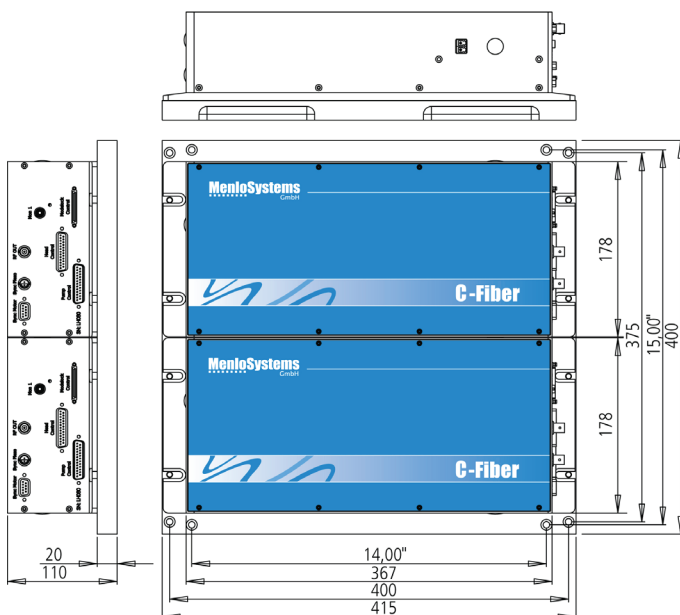

MenloSystems

KEY SPECIFICATIONS

- Wavelength TWIN: 1560 nm
DUAL COLOR 780 nm or 1560 nm
- Time Measurement Window 4 ns or 10 ns
- Repetition Rate 250 MHz or 100 MHz

APPLICATIONS

- Two-Color Pump-Probe Spectroscopy
- Time-Domain THz Spectroscopy
- Material Characterization

FEATURES

- Faster Data Acquisition Times
- Increased Temporal Measurement Windows
- No Moving Mechanical Components (Improved Beam Pointing Stability, Increased Scanning Speed)
- **ASOPS Control Software**
Full Control of the ASOPS Electronics via Graphical User Interface, XML-RPC Interface Enabling Remote Control, Includes PC and Counter

OPTIONS

- **VARIO**
User-Defined Repetition Rate
Factory-set value selectable in the 50-250 MHz range
- **MULTIBRANCH**
Additional Seed Ports
Seeding of multiple amplifiers with optional subsequent frequency conversion to cover multiple wavelengths

ASOPS



Asynchronous Optical Sampling System

SPECIFICATIONS	ASOPS TWIN	ASOPS DUAL COLOR
Repetition Rate	250 MHz	100 MHz
Repetition Rate Offset Tuning Range	$\Delta f = -10 \text{ kHz} \dots +10 \text{ kHz}$, in steps of 10^{-5} Hz	$\Delta f = -10 \text{ kHz} \dots +10 \text{ kHz}$, in steps of 10^{-5} Hz
Time Measurement Window	4 ns	10 ns
Scan Duration 1 / Δf *	0.1 ms @ 10 kHz offset, 1 s @ 1 Hz offset	0.1 ms @ 10 kHz offset, 1 s @ 1 Hz offset
Data Point Increment **	160 fs @ 10 kHz, 0.016 fs @ 1 Hz	1 ps @ 10 kHz, 0.1 fs @ 1 Hz
RMS Timing Jitter [0.1 Hz - 500 kHz]	<150 fs	<150 fs

SPECIFICATIONS LASERHEADS

Wavelength	1560 nm	1560 nm	780 nm
Average Output Power	>75 mW (from each laser)	>100 mW	>100 mW
Output Port	fiber-coupled FC/APC	free space	free space
Pulse Length	<150 fs after 6 m PM fiber	<90 fs	<120 fs
Piezo Tuning Range	>625 Hz	>100 Hz	>100 Hz
Piezo Bandwidth	>30 kHz	>30 kHz	>30 kHz
Stepper Motor Tuning Range	>2 MHz	>330 kHz	>330 kHz
Trigger Signal	TTL level at offset frequency, <10 ns rise time	TTL level at offset frequency, <10 ns rise time	

*Scales inversely with the repetition rate offset. **Scales with the ratio of the repetition rate offset and the repetition rate squared ($\Delta f/f^2$).

REQUIREMENTS

Operating Voltage	110/115/230 VAC	110/115/230 VAC
Frequency	50 to 60 Hz	50 to 60 Hz
Cooling Requirements	no water cooling required	no water cooling required
Operating Temperature	22 \pm 5 °C	22 \pm 5 °C
Optical Unit Dimensions/Weight	415 x 400 x 110 mm ³ , 35 kg	500 x 535 x 110 mm ³ , 35 kg
Control Electronics Dimensions/Weight	mounted in a 19" rack cabinet, 800 x 600 x 1800 mm ³ , 75 kg	mounted in a 19" rack cabinet, 800 x 600 x 1800 mm ³ , 75 kg

ORDERING INFORMATION

Product Code	ASOPS TWIN	ASOPS Dual Color
--------------	------------	------------------

Please call for pricing. Specifications are subject to change without notice. Custom modifications are available, please inquire.



Invisible laser radiation
avoid exposure to beam
Class 4 laser



Menlo Systems GmbH
T+49 89 189 166 0
sales@menlosystems.com

Menlo Systems, Inc.
T+1 973 300 4490
ussales@menlosystems.com

Thorlabs, Inc.
T+1 973 579 7227
sales@thorlabs.com

