

Repetition Rate Synchronization Electronics RRE100



Synchronize your pulsed laser sources with highest accuracy: the Menlo Systems RRE100 provides state-of-the-art phase lock electronics. It's a complete, user-friendly system that allows for plug & play use.

We have developed the Repetition Rate Synchronization for the patented, Nobel Prize awarded Optical Frequency Synthesizer technology. The RRE100 has been field-tested in this highly demanding environment enabling measurements with precisions never reached before.

The main application is the synchronization of a pulsed laser to a radio frequency reference, derived from a radio frequency clock or an optical reference clock. To demonstrate its capability two femtosecond fiber lasers were synchronized to each other with the phase lock technique with a timing jitter of significantly less than 100 fs.*

* Synchronization of two mode-locked Menlo Systems TC1550 femtosecond fiber lasers, timing jitter < 11 fs, 4 Hz to 5 kHz bandwidth, measurement time 0.25 seconds.

Features

- Fully automated one button solution
- Phase locks your laser to a fixed repetition frequency synchronized to external 10 MHz reference
- Embedded microcontroller for stepper motor and Piezo control in laser cavity ensuring long-term stability

Options

- Custom reference frequencies
- Adjustable offset to set the relative time delay between the laser pulses, enabling time-resolved experiments without using a mechanical delay stage
- Synchronization of a laser to tunable repetition rate

Repetition Rate Phaselocked to Reference Frequency

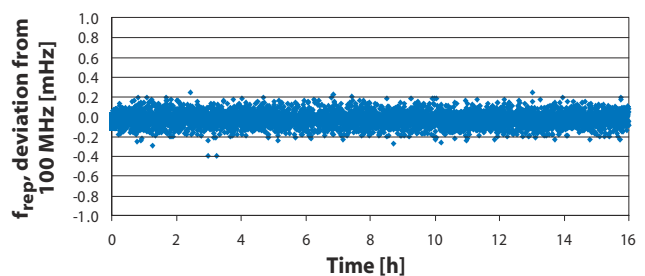

Applications

Synchronization of your pulsed laser source to a master clock, either from the radio or optical domain

Metrology

Allows for generation of stabilized frequency combs. The RRE has been developed for and is an integral part of the Menlo Systems Optical Frequency Synthesizers FC8004 and FC1500.

Accelerator Facilities

Allows for electrooptical sampling of particle bunches by synchronization of light sources to particle beams.

Pulsed X-ray Facilities

Allows for seeding free-electron lasers and for experimental sample excitation.

Ultrafast Time-domain Spectroscopy

Minimizes the relative jitter between the pulses of two or more light sources.
Opens up the high-speed asynchronous optical sampling (ASOPS) technique.

Repetition Rate Synchronization Electronics RRE100

TECHNICAL SPECIFICATIONS

RMS Timing Jitter	<200 fs (10 Hz–1 MHz) or same as reference, whichever applies first*
INPUTS	
External Reference Input	10 MHz** (provided by customer) signal level +5... +10 dBm
Repetition Rate Input	Signal level -20...-10 dBm
OUTPUTS	
Repetition Rate Signal	Amplified, can be directly connected to e.g. a frequency counter, BNC
Stepper Motor Signal	Stepper motor control, Sub-D, 9 pin
Piezo Signal	Piezo control, BNC
Error Signal	Error signal for monitoring, BNC
Power Requirements	110/220 V
Storage Temperature	0... + 40 °C
Dimensions	449 x 148 x 317 mm ³
Weight	7 kg
Remote Control	Unit can be connected to a PC via the RS232 interface

* Values specified for TC1500 and TC780 femtosecond fiber lasers of Menlo Systems GmbH. Please contact us when stabilizing lasers from other manufacturers to optimize performance of RRE100.

** For custom reference frequencies please contact us.

Schematic Setup

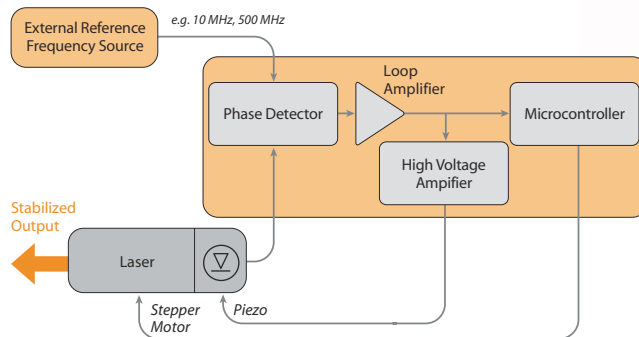

RRE 100

ORDERING INFORMATION

RRE100	Repetition Rate Synchronization for synchronization of a pulsed laser to a 10 MHz frequency reference	EUR 9,400
---------------	---	------------------

For custom reference frequencies, adjustable offset, synchronization to a tunable repetition frequency please call and inquire about our modular Repetition Rate Synchronization product.

call for pricing

For custom modifications and OEM quantities please call for pricing. Prices and Specifications are subject to change without notice.

Contact

Menlo Systems GmbH
Am Klopferspitz 19
D-82152 Martinsried/Munich
Germany
Tel: +49 89 189166 -0
Fax: +49 89 189166 -111
www.menlosystems.com
sales@menlosystems.com

In the US

Menlo Systems Inc.
Tel: +1-973-300-4490
www.menlosystems.com
ussales@menlosystems.com
Thorlabs, Inc.
Tel: +1-973-579-7227
www.thorlabs.com
sales@thorlabs.com

In Japan & Asia

Thorlabs Japan Inc.
Tel: +81-3-5977-8401
www.thorlabs.com
sales@thorlabs.jp